

# UREĐENJE SOLINA I TRAVARICE

NATJEČAJ ZA IZRADU IDEJNOG URBANISTIČKO - ARHITEKTONSKOG RJEŠENJA  
UREĐENJA KULTURNO-POVLJESNE CJELINE SOLINA I TRAVARICE U TROGIRU

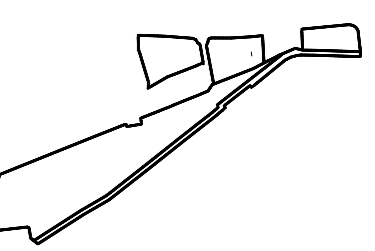

SITUACIJA 1:1000

URBANIZAM

- obuhvat
- popisne linije
- PROMET
- kočni ulazidat
- kontrola pristupa
- parking za bicikle
- stajališta vatrogasnih vozila
- POCNE OBLOGE
- kameno popločenje
- asfalt
- stabilizer - podloga za igru i šetnju
- održavna drvena šetnica
- šljunak i šipra
- pijesak
- možuća mjesta za dodatne paviljone

ZELENILO

- risko i grmoticno raslinje
- stabilna postojeca
- stabilna nova
- fotovoltačni paneli

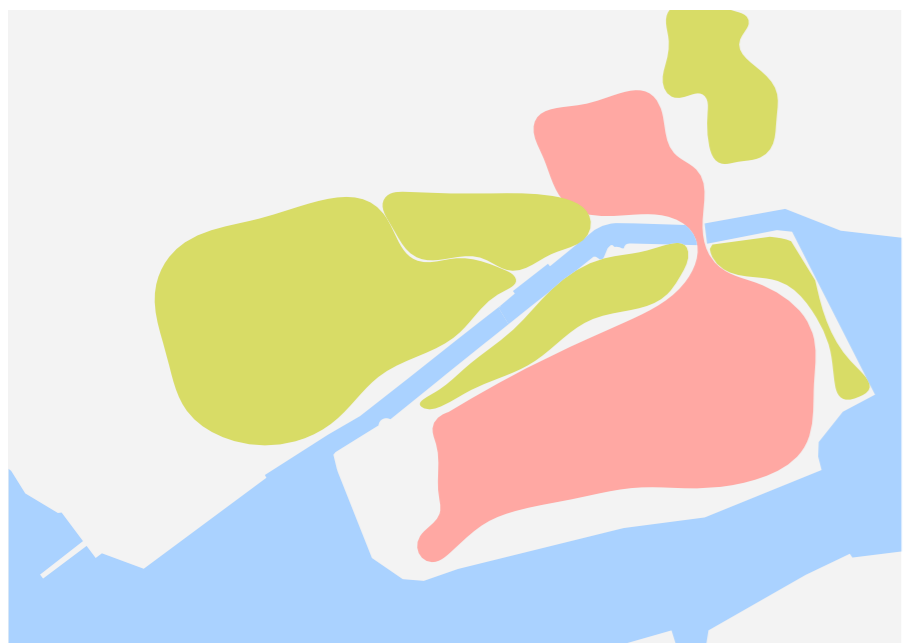
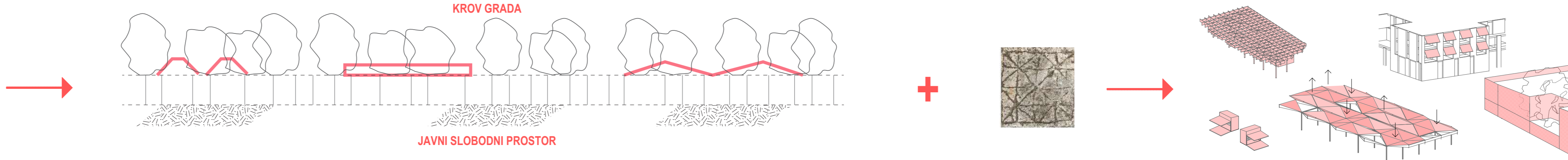
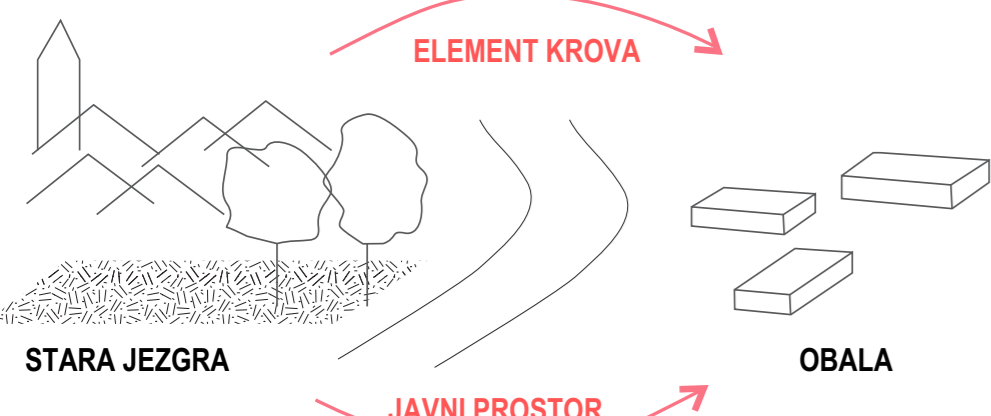
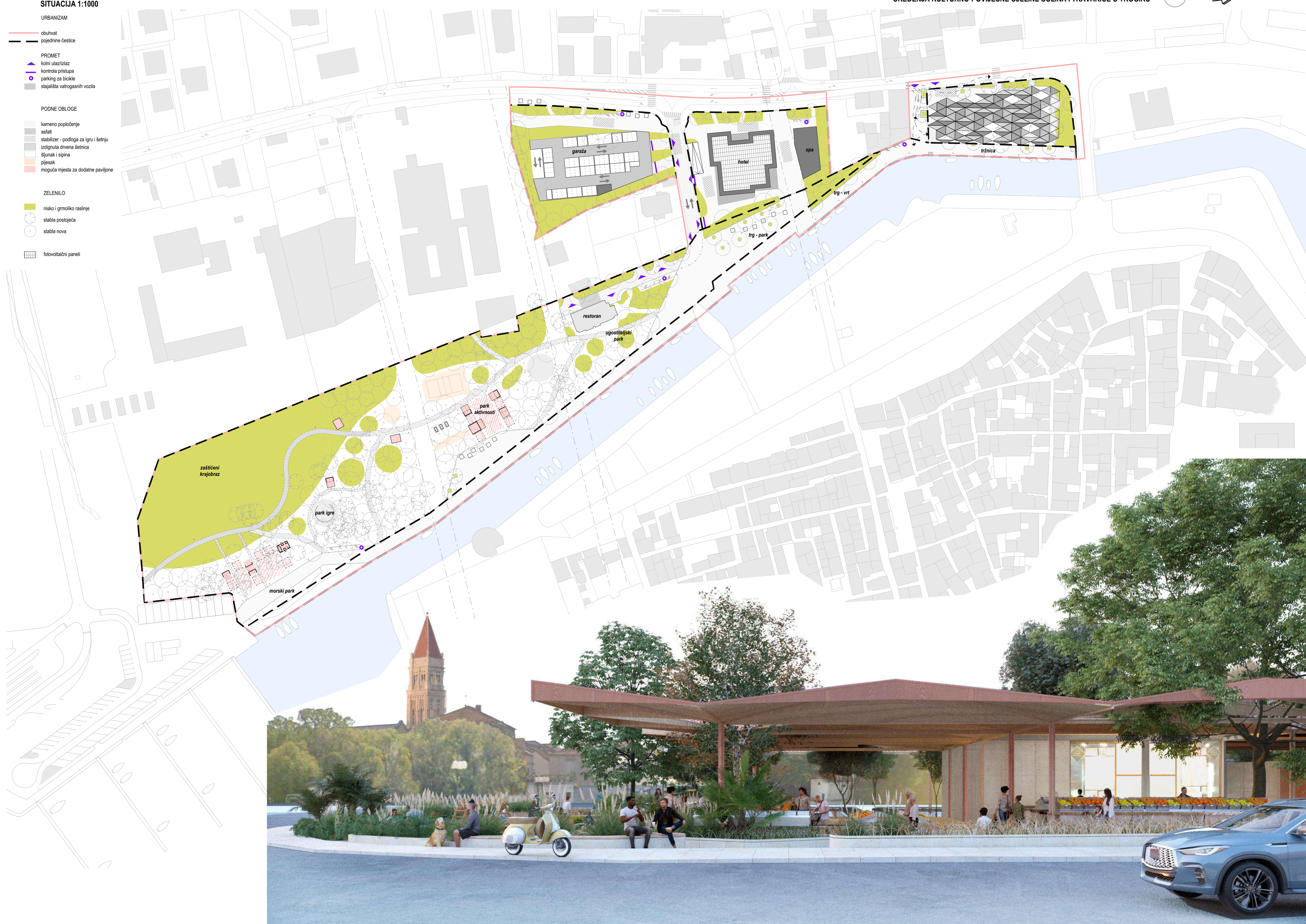

**KROŠNJE I KROVOVI**  
Natkriivanje prostora nastavkom započete urbane matrice - krovovi u staroj jezgri koji su se 'izlili' i na kontaktnu zonu, te krošnje koje natkrivaju javni prostor parka i okolnih površina

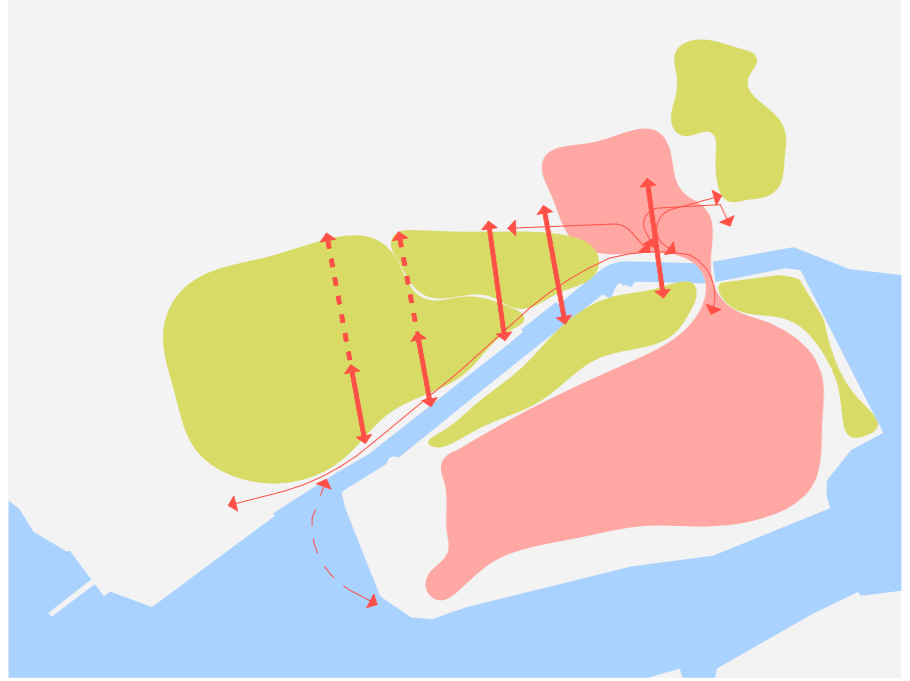

**INTEGRIRANJE OBUHVATA U GRADSKO TKIVO**  
Povezivanje obuhvata na nivou partera sa okolnim prostorima i sadržajima. Obuhvat postaje vezivno tkivo grada.

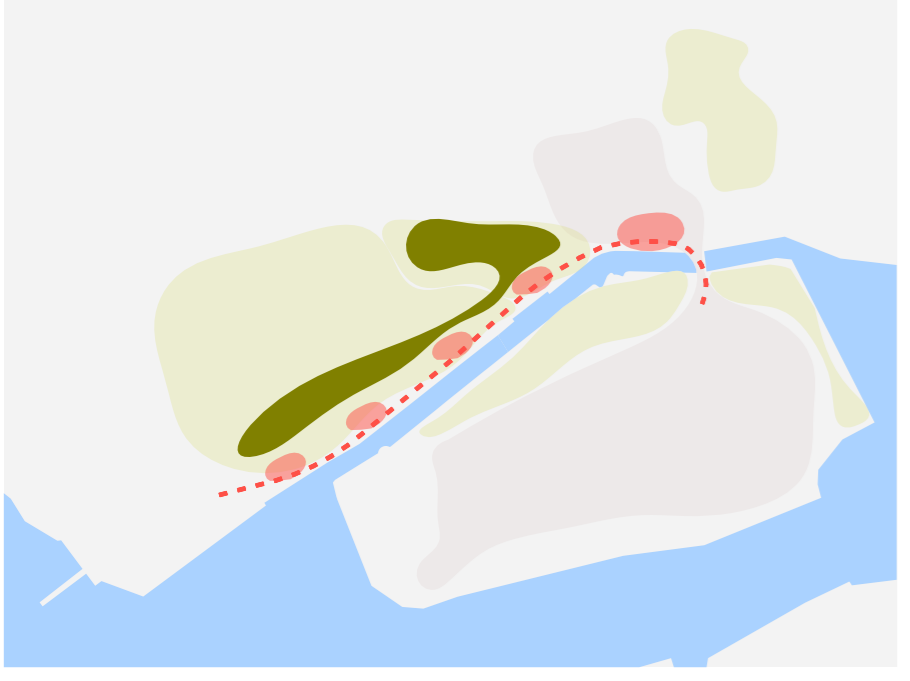

**SISTEM JAVNIH POVRŠINA - PARKOVI I TRGOVI**  
Unutar obuhvata uspostavljen je sustav javnih površina - linearnih i stacionarnih - uz Fošu. U njihovom zaleđu smješteni su programi oslobađajući glavne pješake tokove za spontane susrete i zadržavanja.

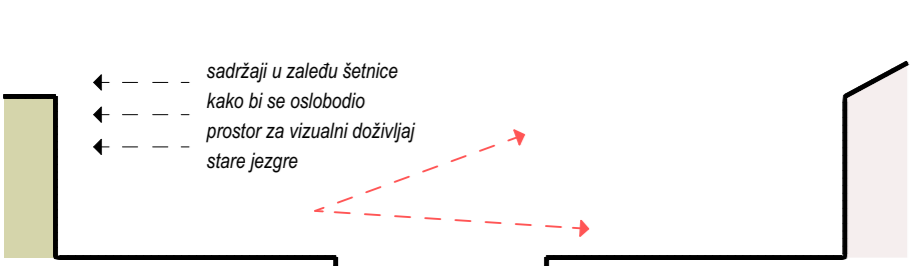

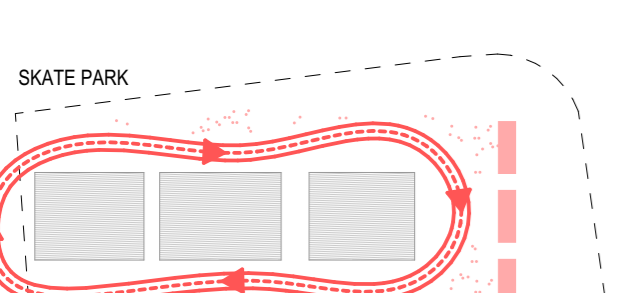
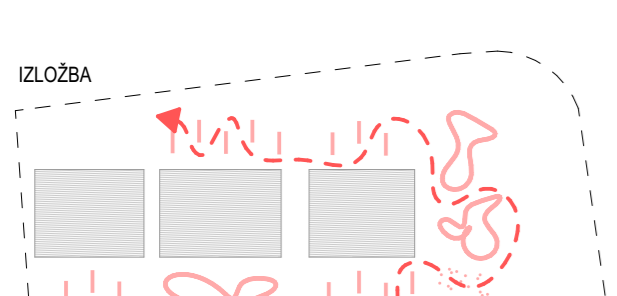
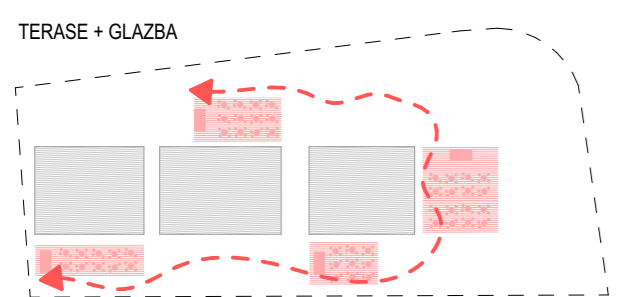
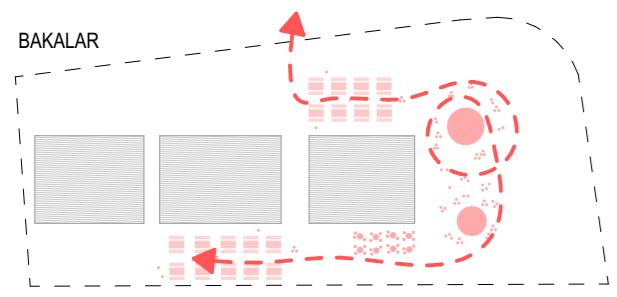
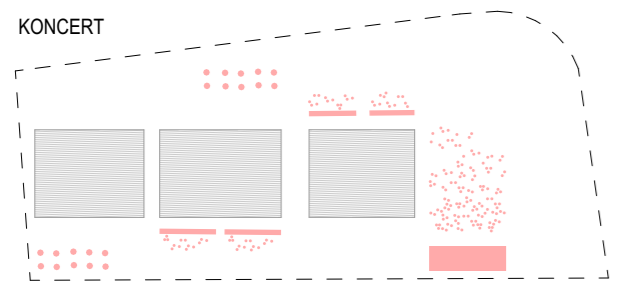
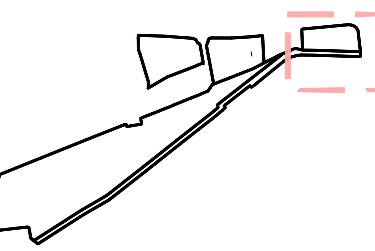

scenariji korištenja prostora tržnice

- kamen
- zaglađeni beton
- pijesak
- šljunak
- kamen+šljunak
- rešetka za stablo, metalna
- rasvjeta
- zelena površina
- stabilizer
- asfalt



TLOCRT PRIZEMLJA TRŽNICE 1:200

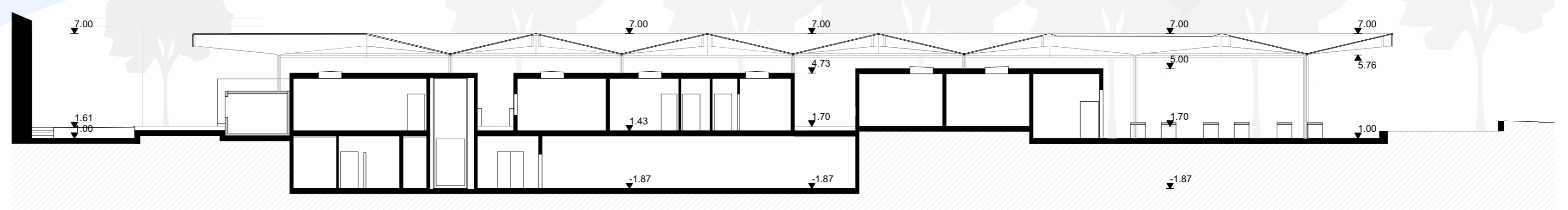

PODUŽNI PRESJEK 1:200

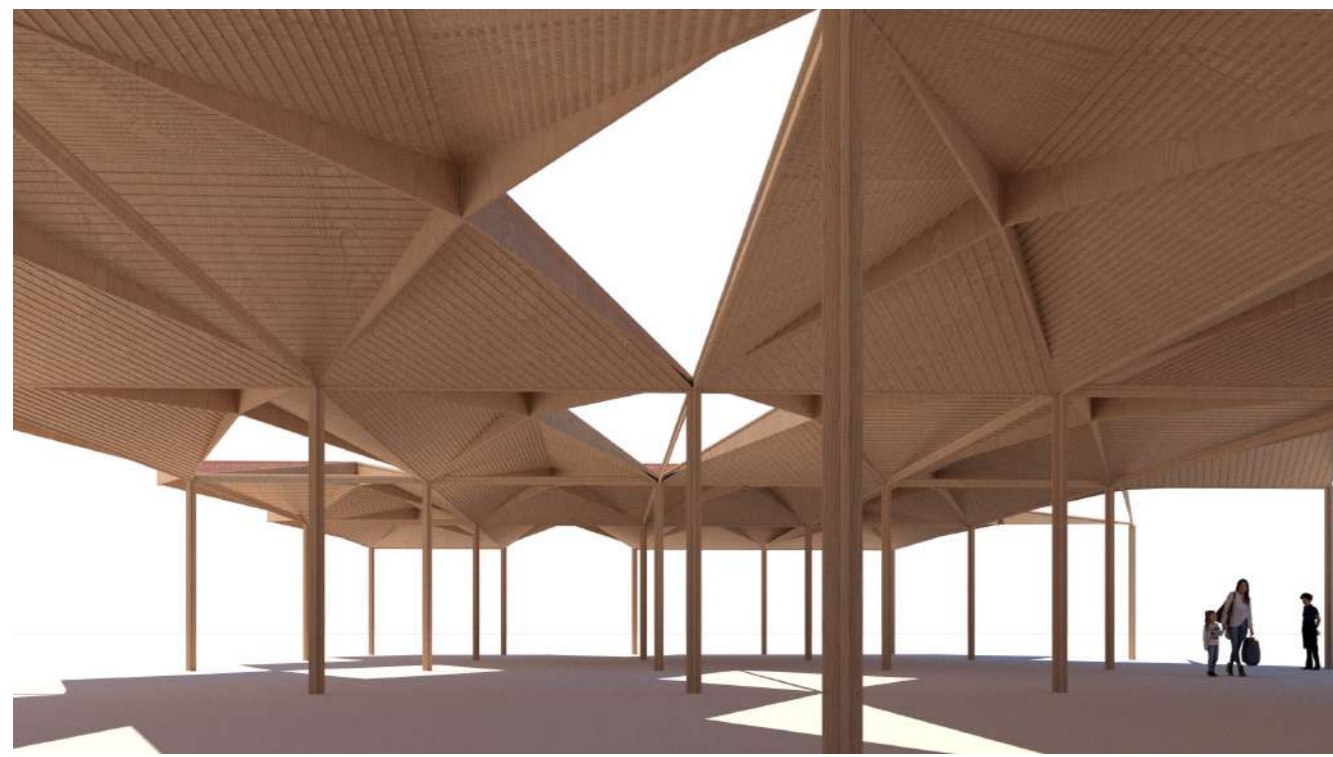

PROČELJE JUG 1:200



PROČELJE ISTOK 1:200



PROČELJE SJEVER 1:200

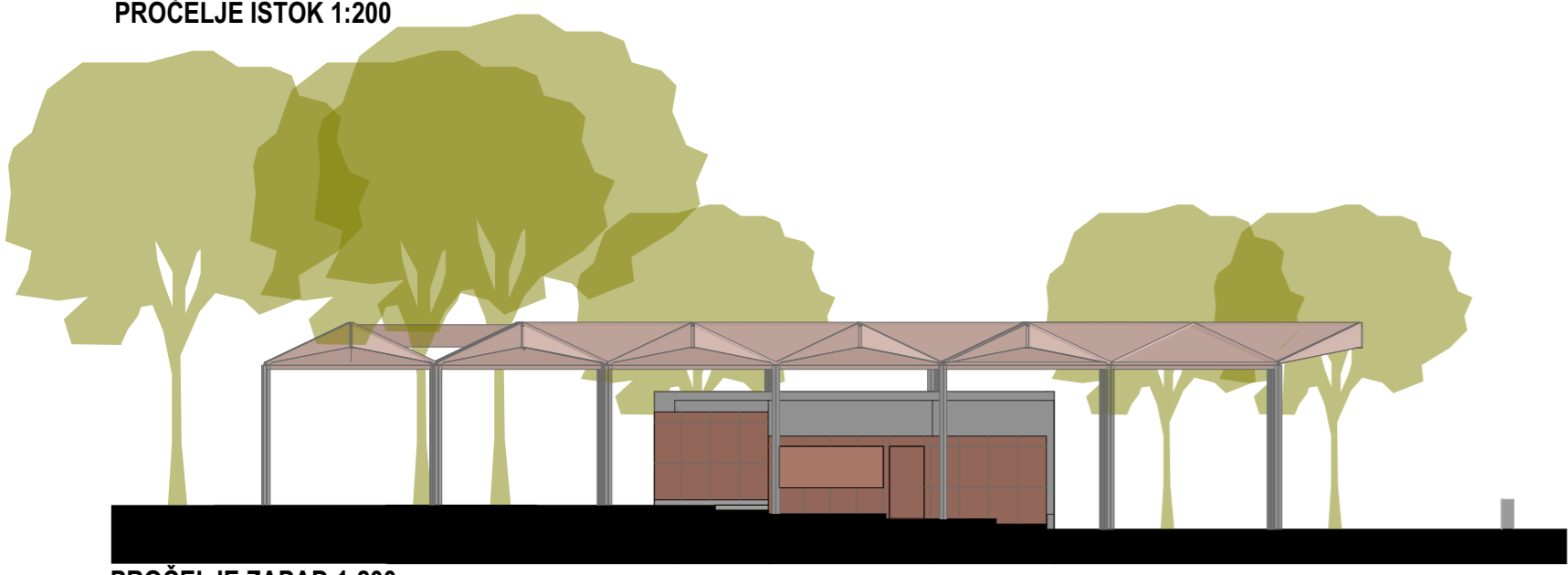

PROČELJE ZAPAD 1:200

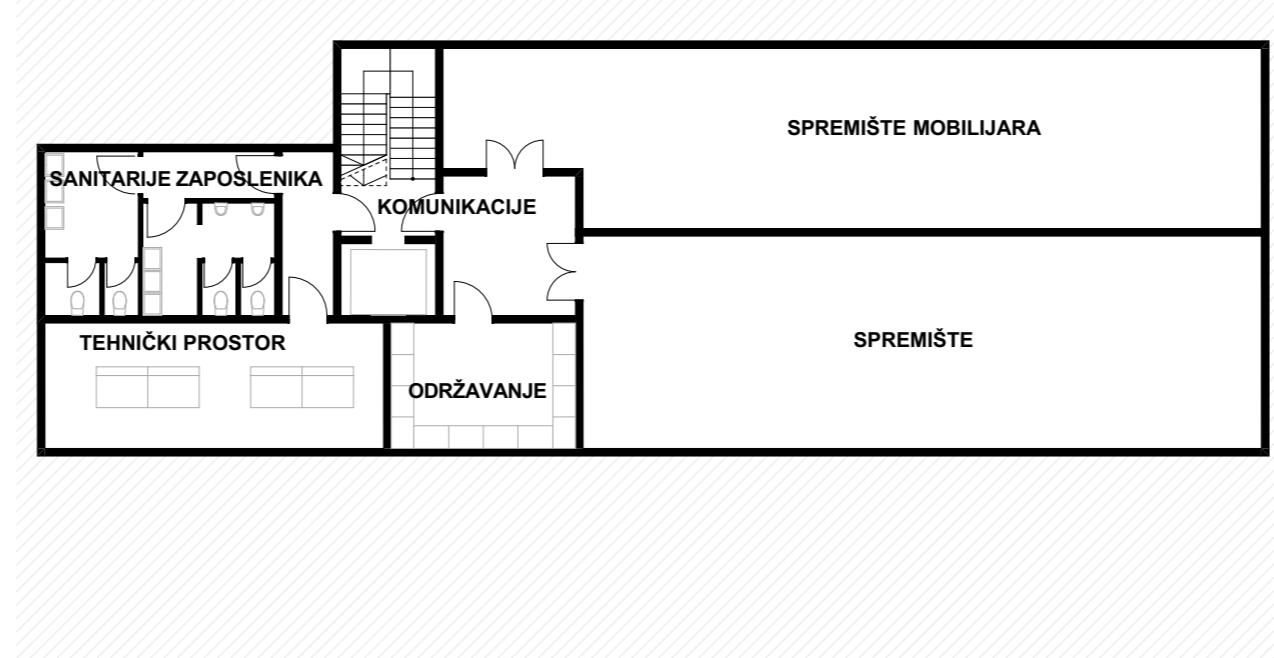

TLOCRT PODRUMA 1:200

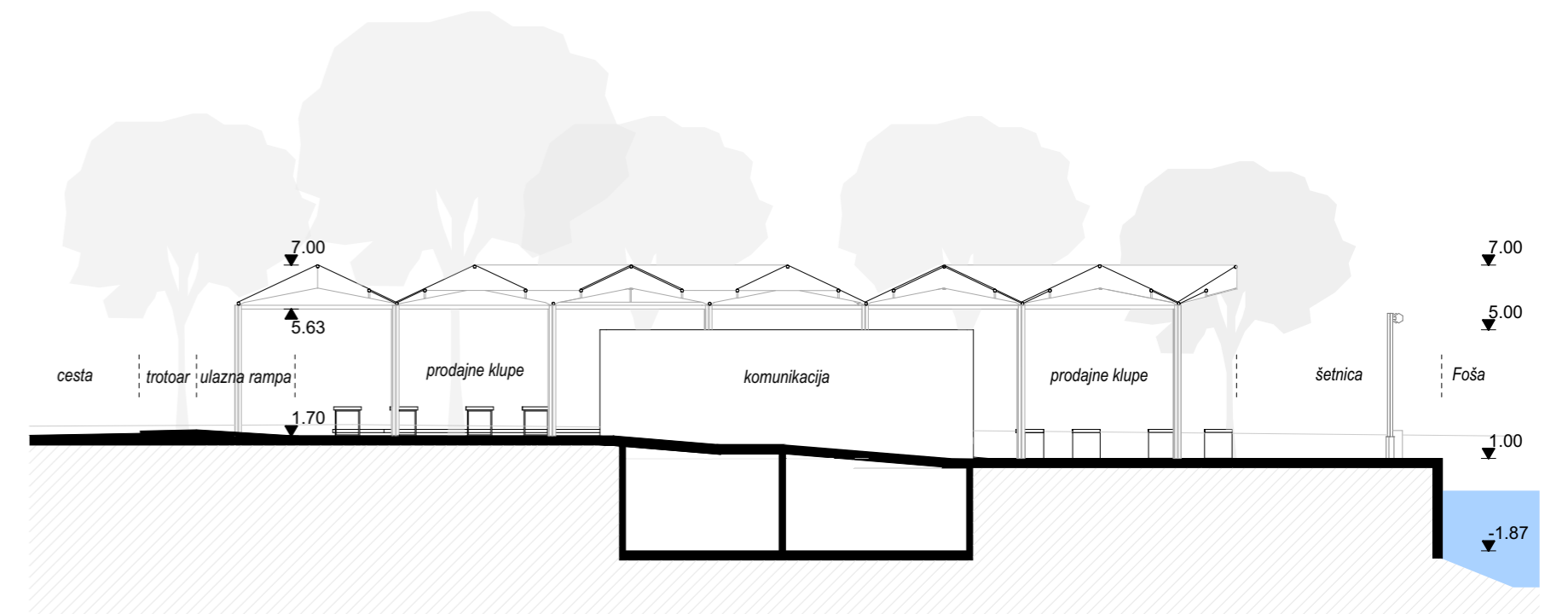

POPREČNI PRESJEK 1:200

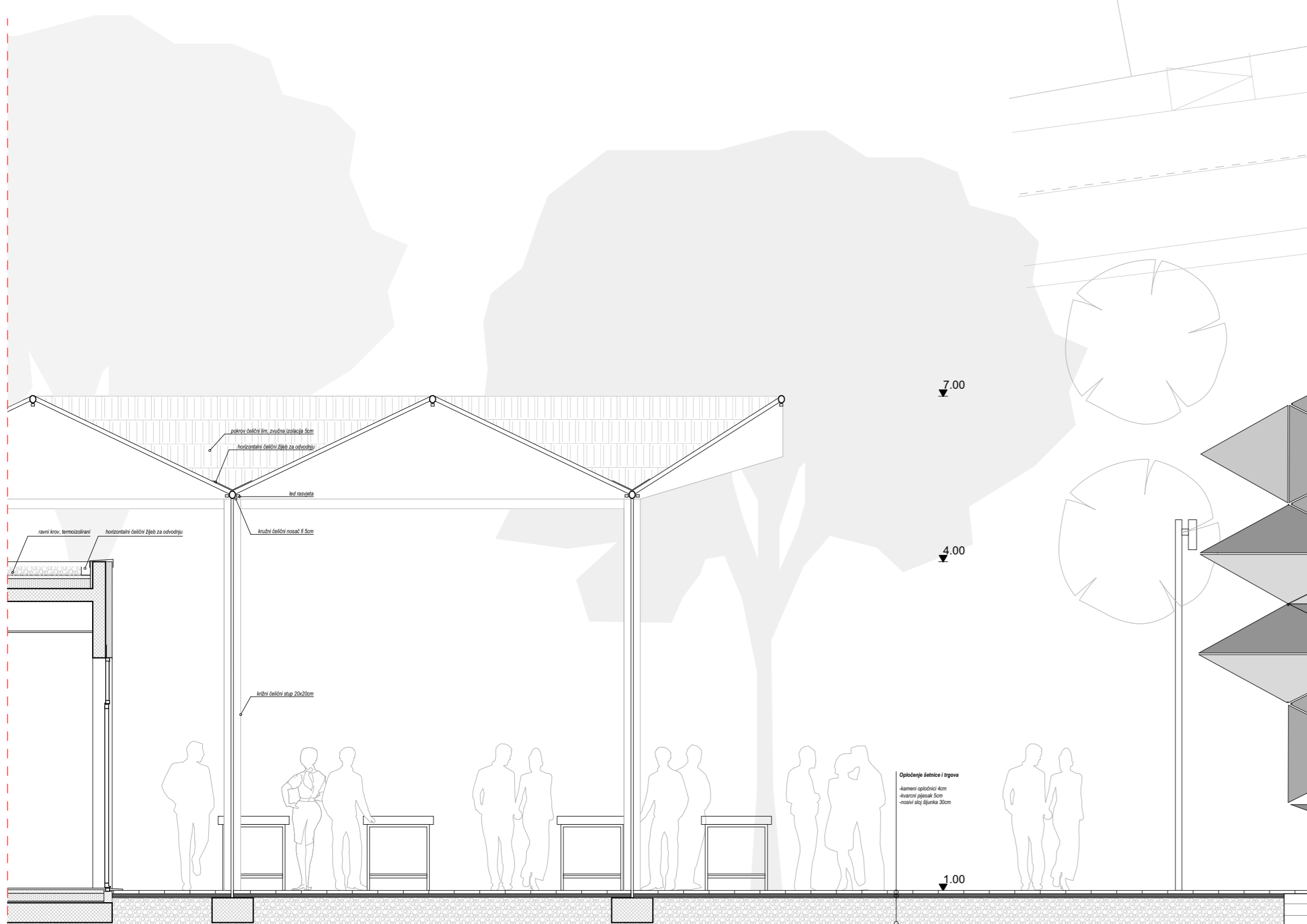

DETALJ 1:50

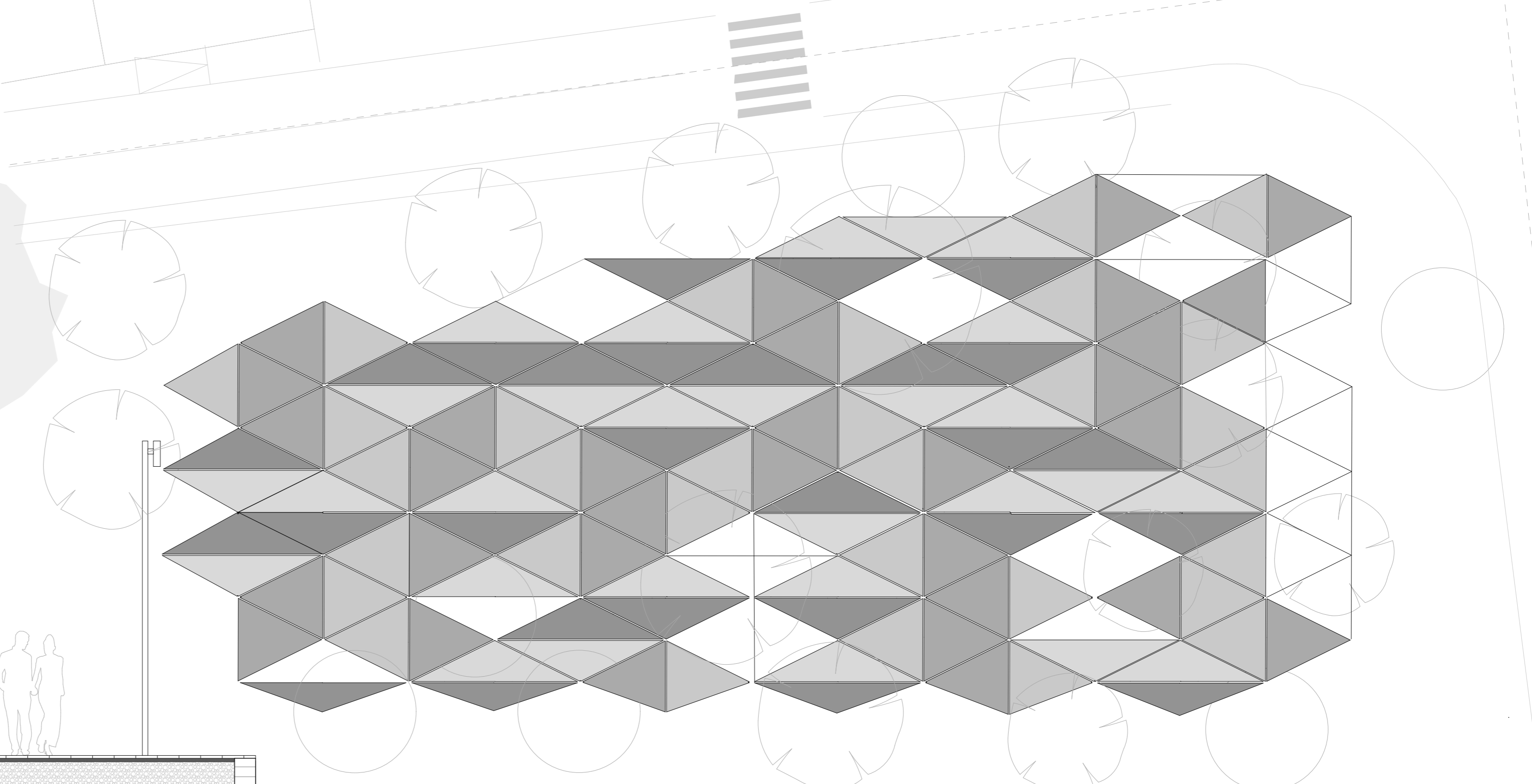

TLOCRT KROVA 1:200



# UREĐENJE SOLINA I TRAVARICE

NATJEČAJ ZA IZRADU IDEJNOG URBANISTIČKO - ARHITEKTONSKOG RJEŠENJA  
UREĐENJA KULTURNO-POVIJESNE CJELINE SOLINA I TRAVARICE U TROGIRU

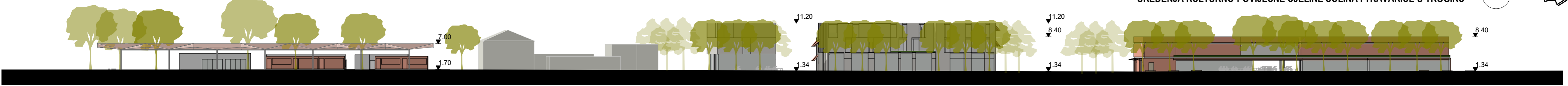
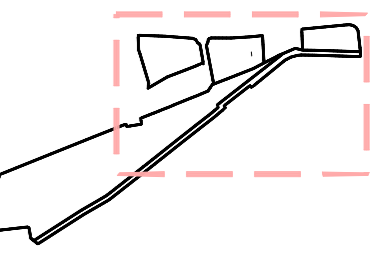

URBANISTIČKO PROČELJE SJEVER 1:500

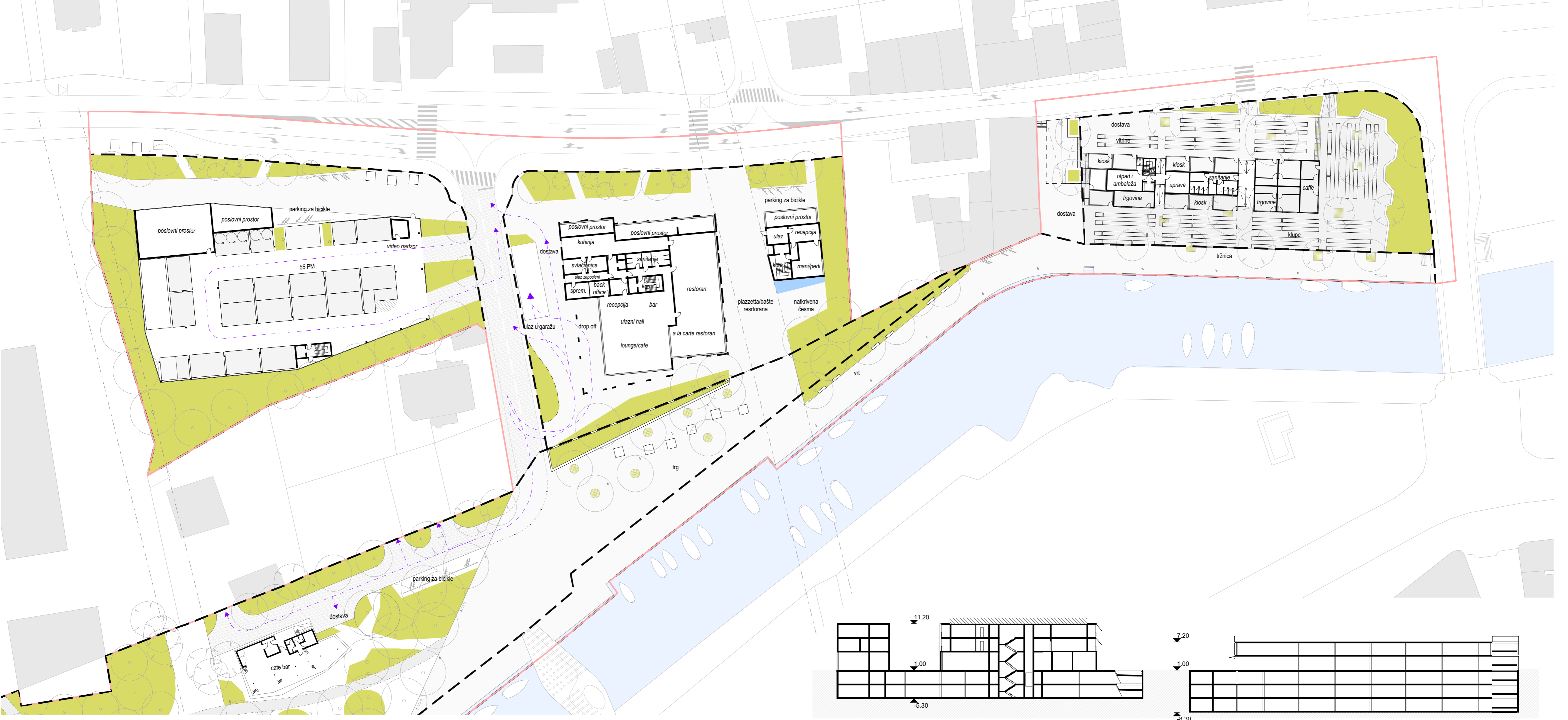

SITUACIJA 1:500

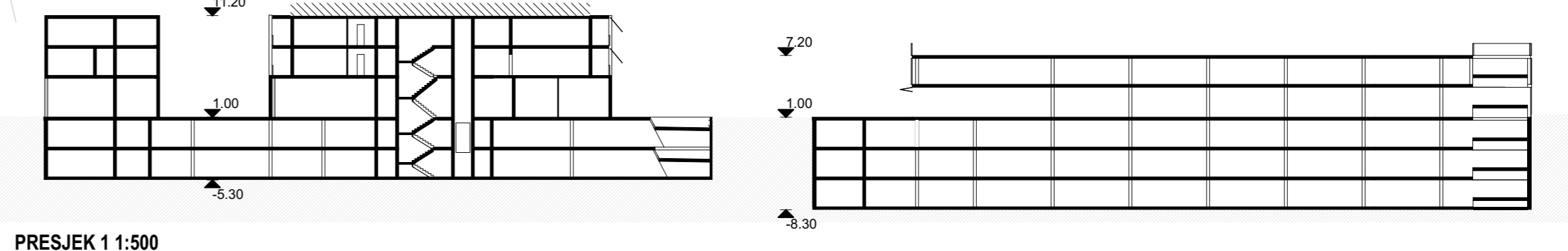

PRESJEK 1 1:500

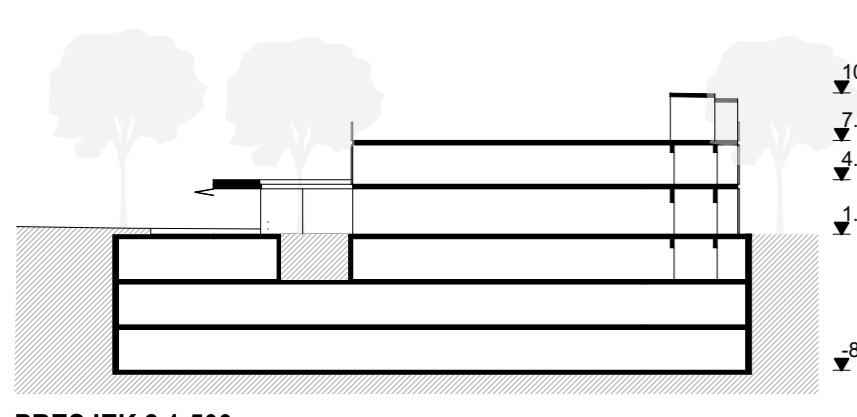

PRESJEK 2 1:500

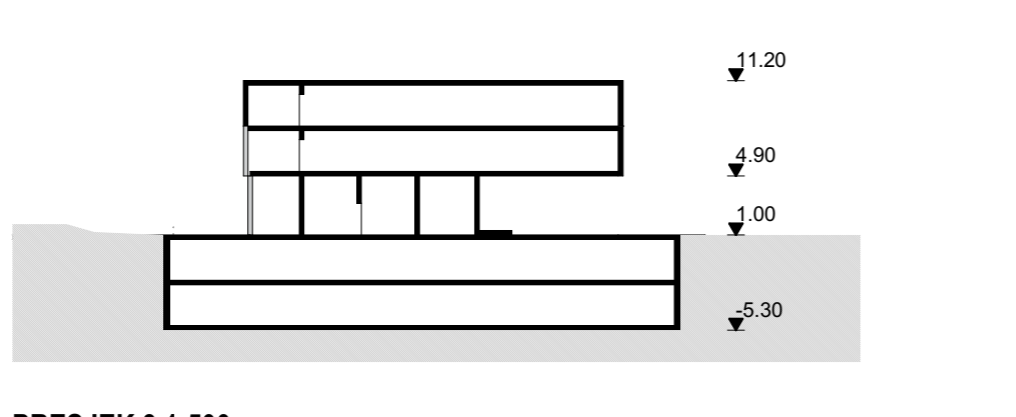

PRESJEK 3 1:500

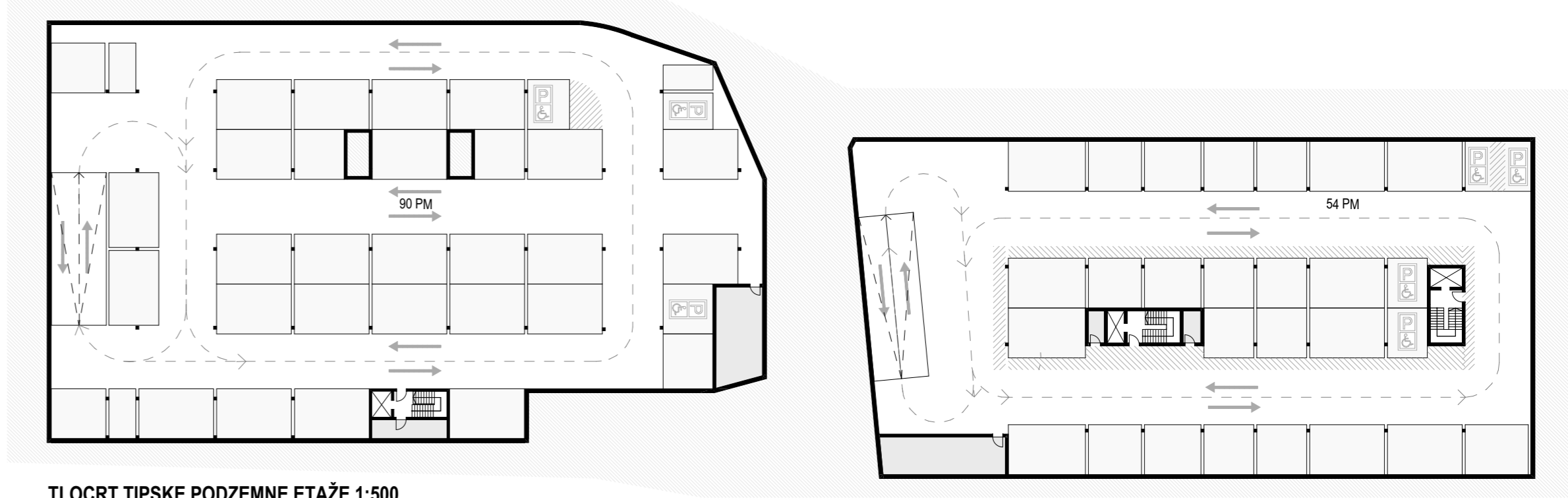

TLOCRT TIPŠKE PODZEMNE ETAŽE 1:500

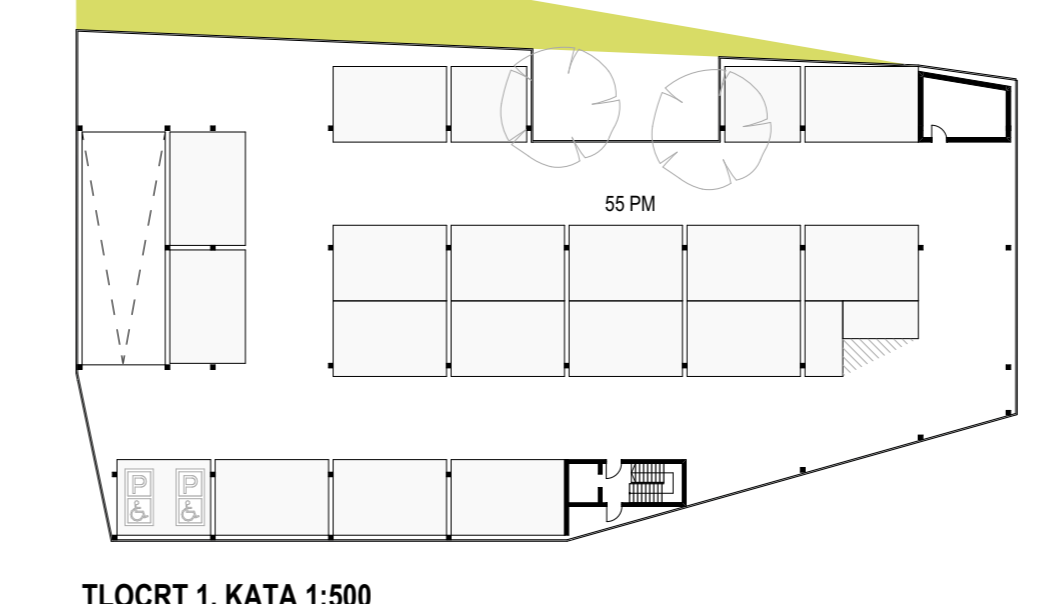

TLOCRT 1. KATA 1:500

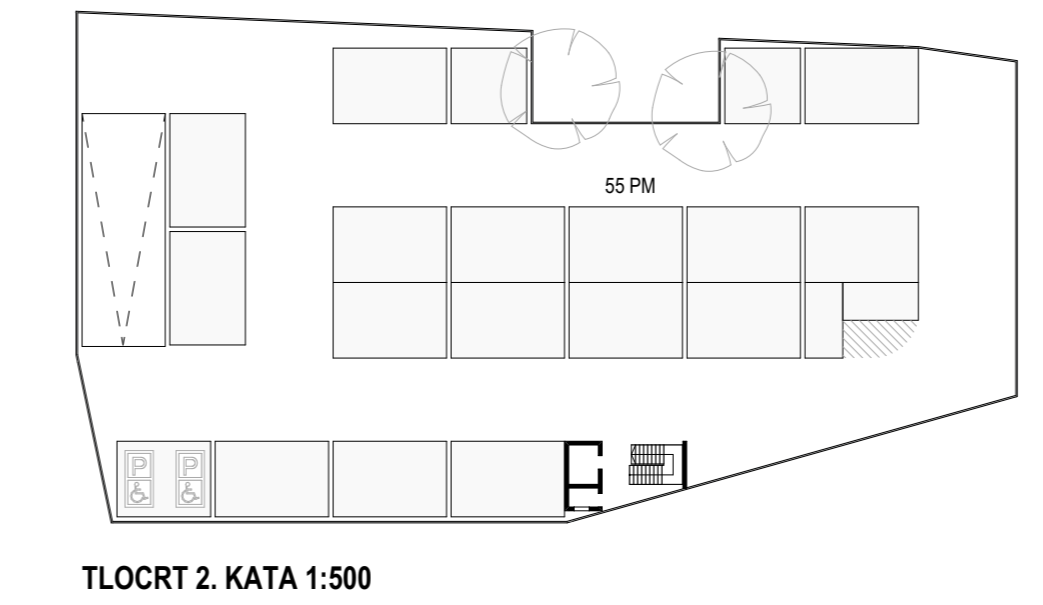

TLOCRT 2. KATA 1:500

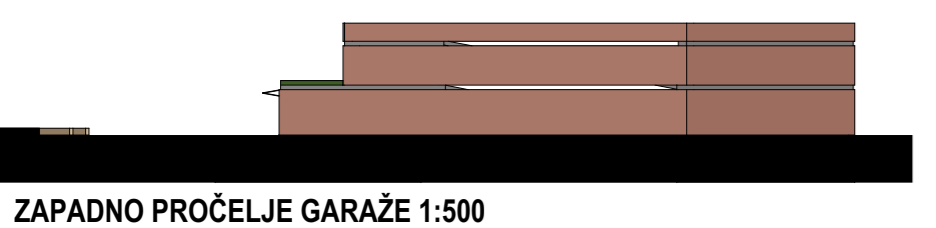
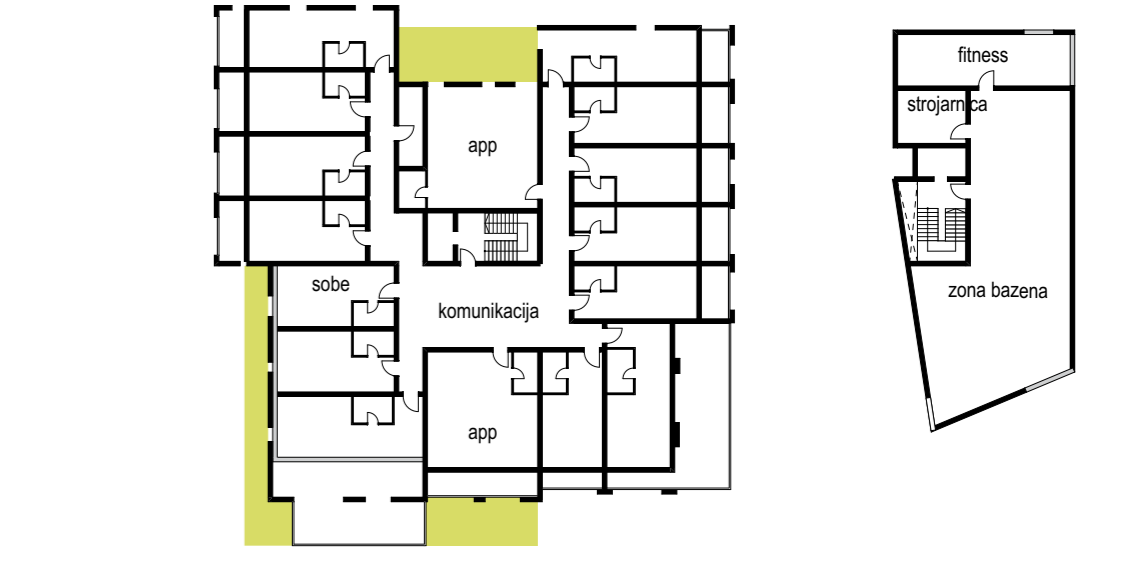

ZAPADNO PROČELJE GARAŽE 1:500



ZAPADNO PROČELJE SPA 1:500

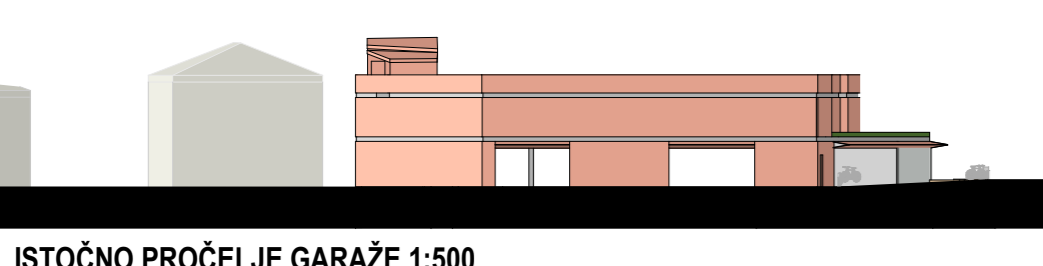

ISTOČNO PROČELJE GARAŽE 1:500

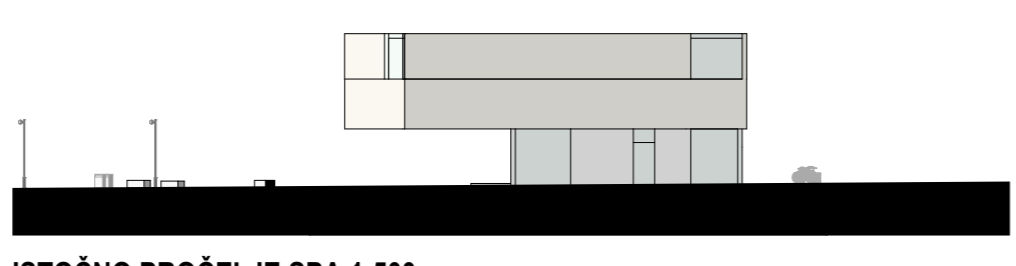

ISTOČNO PROČELJE SPA 1:500

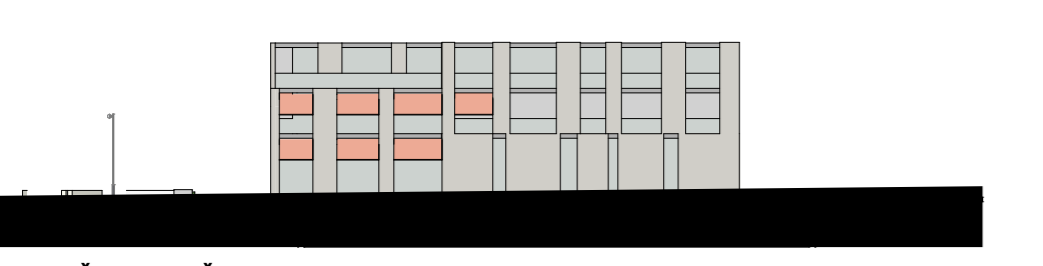

ISTOČNO PROČELJE HOTELA 1:500



ZAPADNO PROČELJE HOTELA 1:500

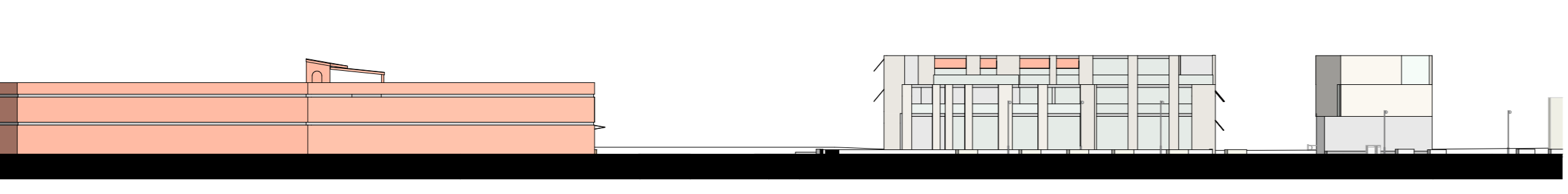

JUŽNO PROČELJE 1:500



# UREĐENJE SOLINA I TRAVARICE

NATJEČAJ ZA IZRADU IDEJNOG URBANISTIČKO - ARHITEKTONSKOG RJEŠENJA UREĐENJA KULTURNO-POVIJESNE CJELINE SOLINA I TRAVARICE U TROGIRU

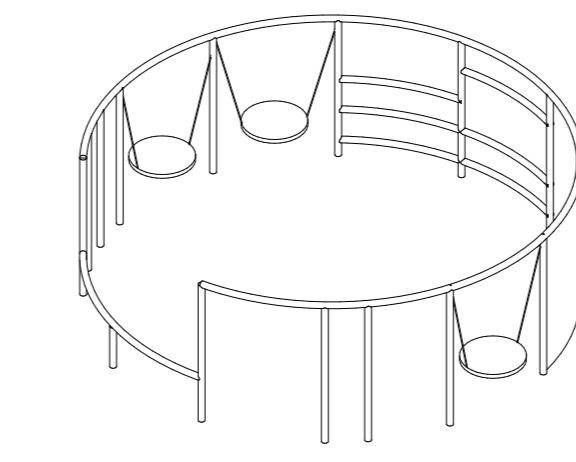
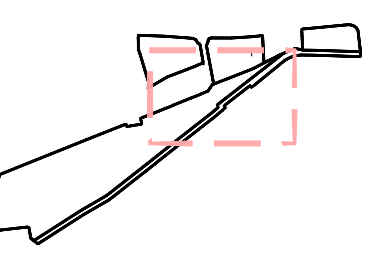

DJEČJE IGRALIŠTE - čelična konstrukcija sa ljuštarkama i mrežama za penjanje

## URBANA OPREMA

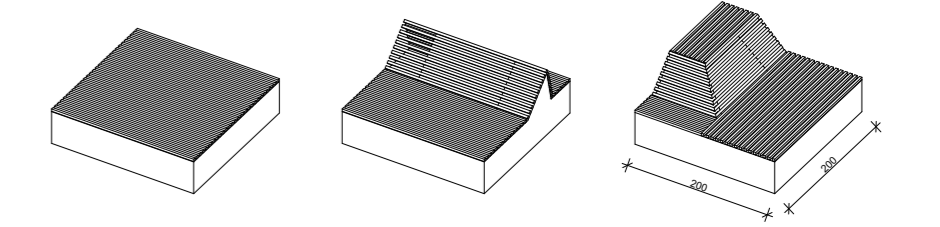
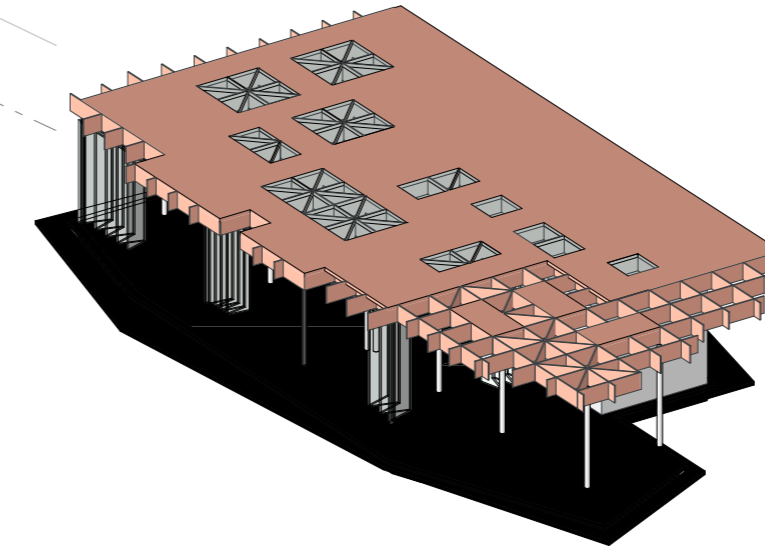

KLUPE ZA VEĆI BROJ LUDI Ili SUNČANJE - betonske postolje sa drvenim letricama

## CAFFE BAR

pokrivni sloj - termopaneli u padu

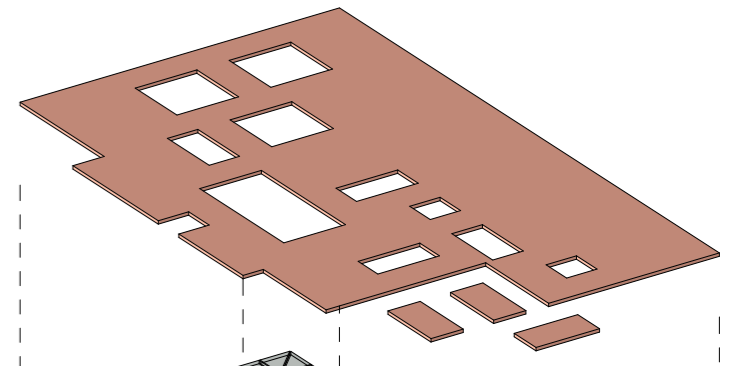

svjetlopropusni sloj - termosastaklo u čeličnim profilima

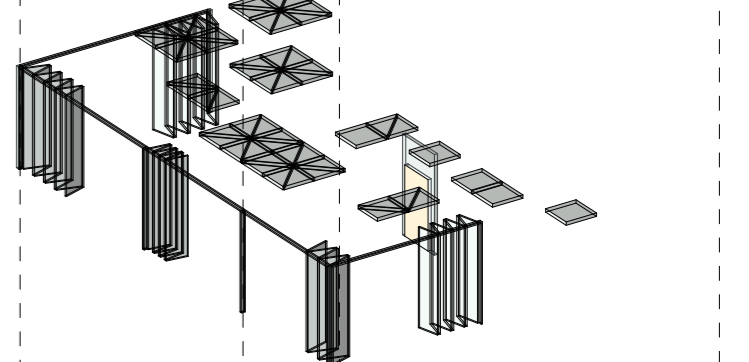

nosivi sloj - čelični nosači

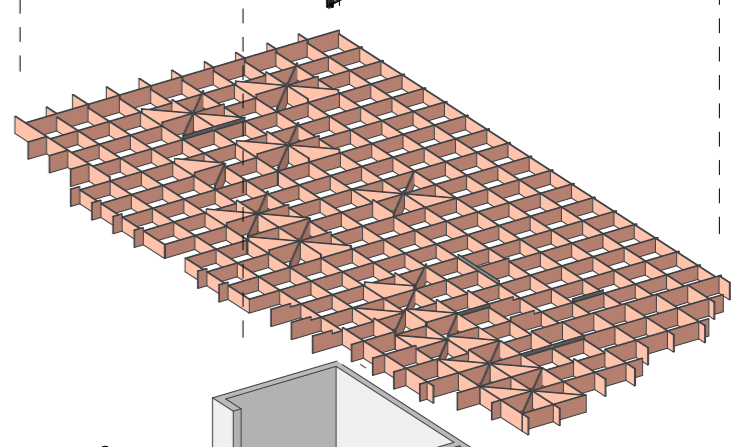

nosivi sloj - čelični stupovi + ab zidovi

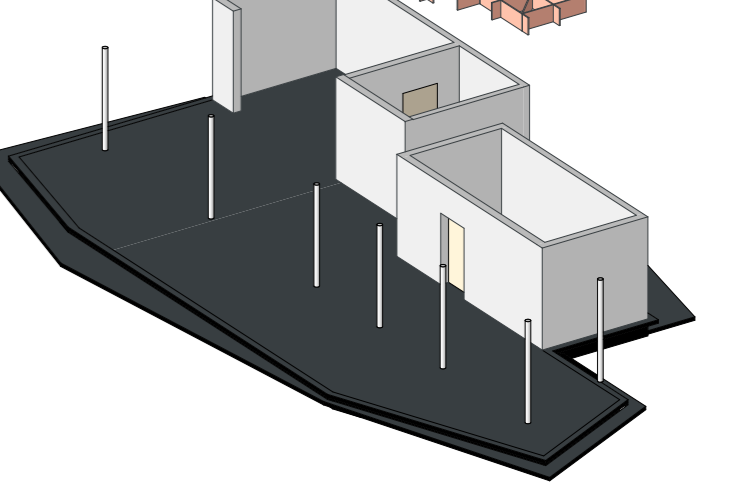

Isotri krova 1:200

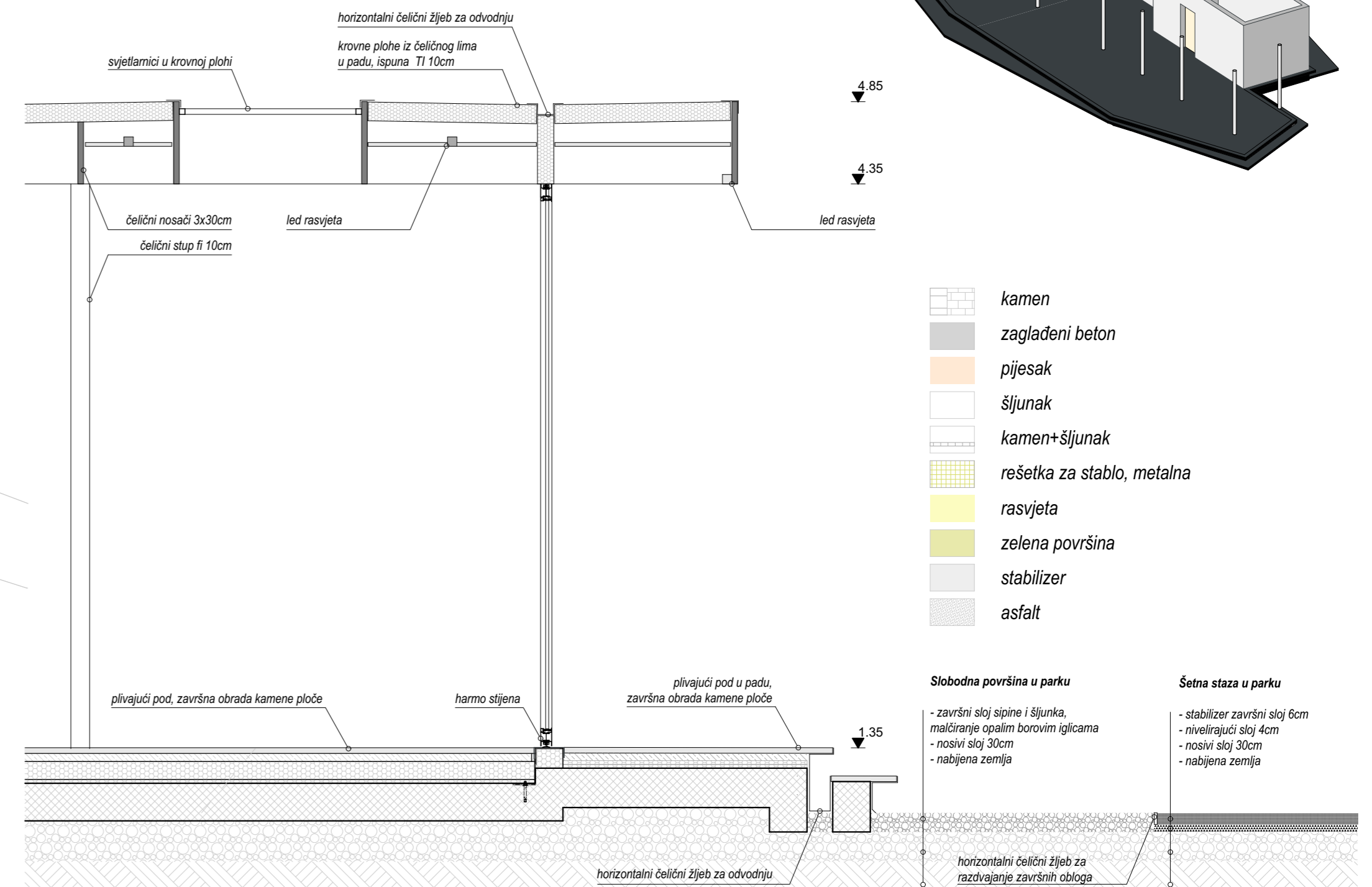

- kamen
- zaglađeni beton
- pijesak
- šljunak
- kamen+šljunak
- rešetka za stablo, metalna
- rasvjeta
- zelena površina
- stabilizer
- asfalt

Slobodna površina u parku  
 - završni sloj šljunka i šljunka  
 - ravniranje opalim borovim iglicama  
 - nosivi sloj 30cm  
 - nabijena zemlja

Šetna staza u parku  
 - stabilizer završni sloj 6cm  
 - ravnajući sloj 4cm  
 - nosivi sloj 30cm  
 - nabijena zemlja

detalj 1:25

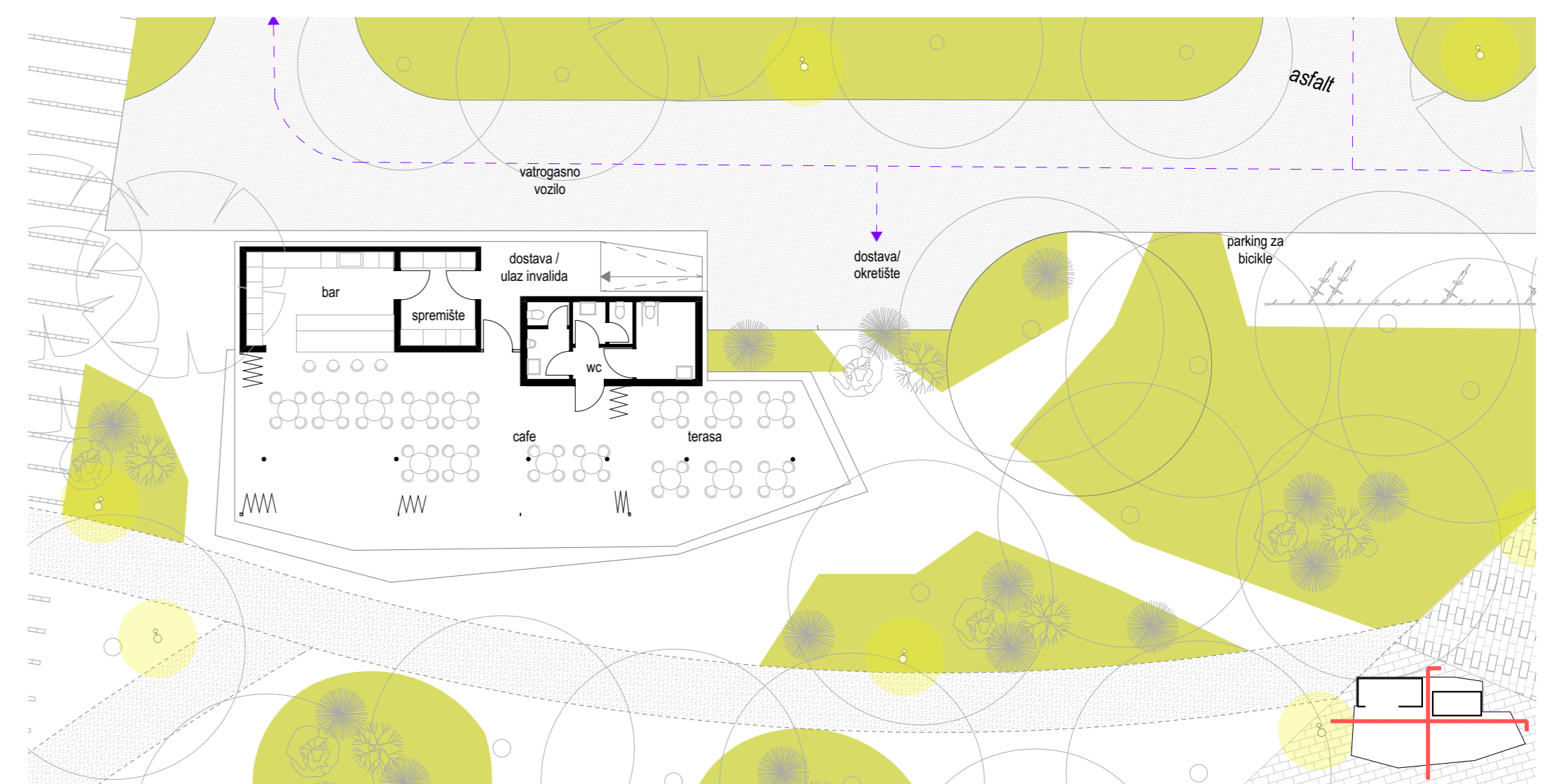

Isotri prizemlja 1:200

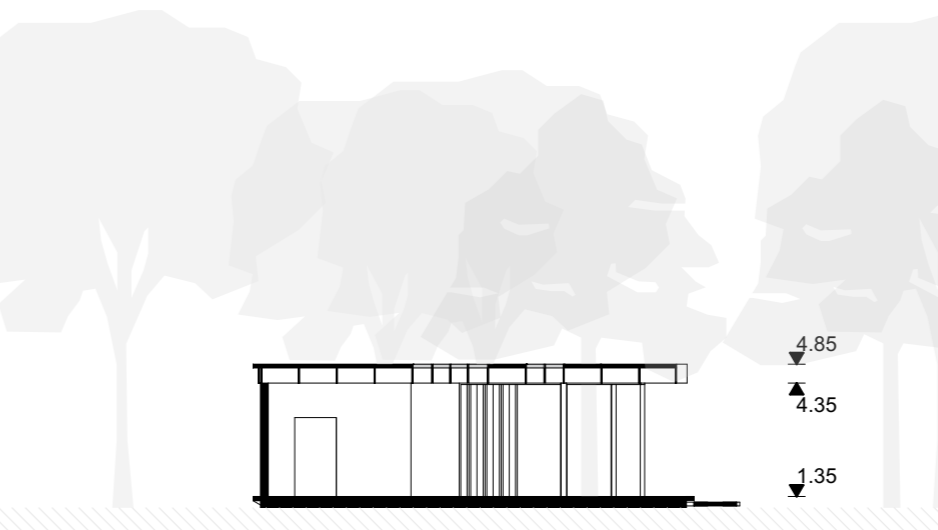

poprečni presjek 1:200

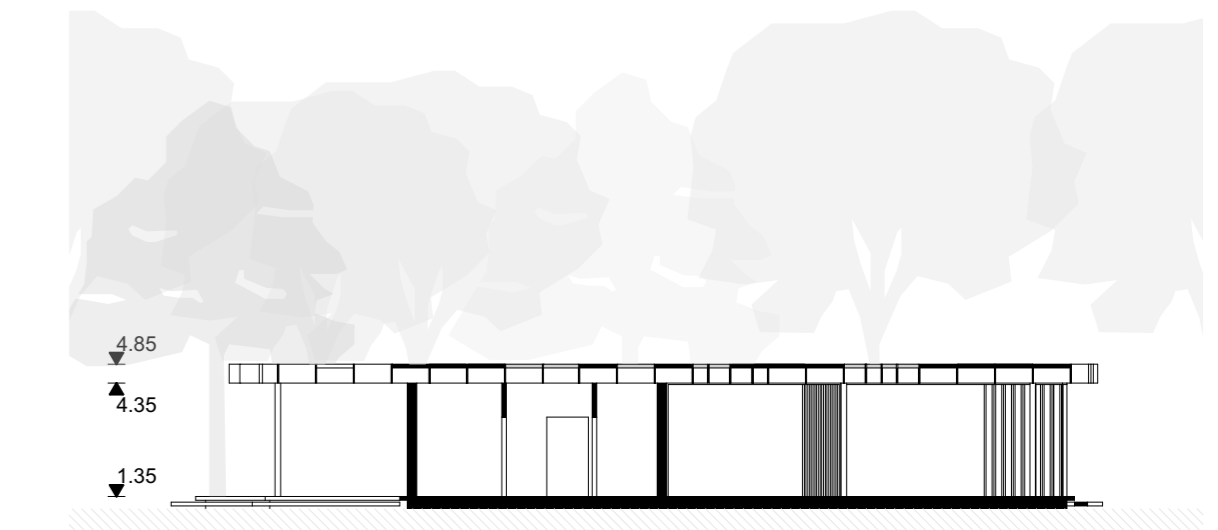

podni presjek 1:200



zapadno pročelje 1:200



južno pročelje 1:200



istočno pročelje 1:200

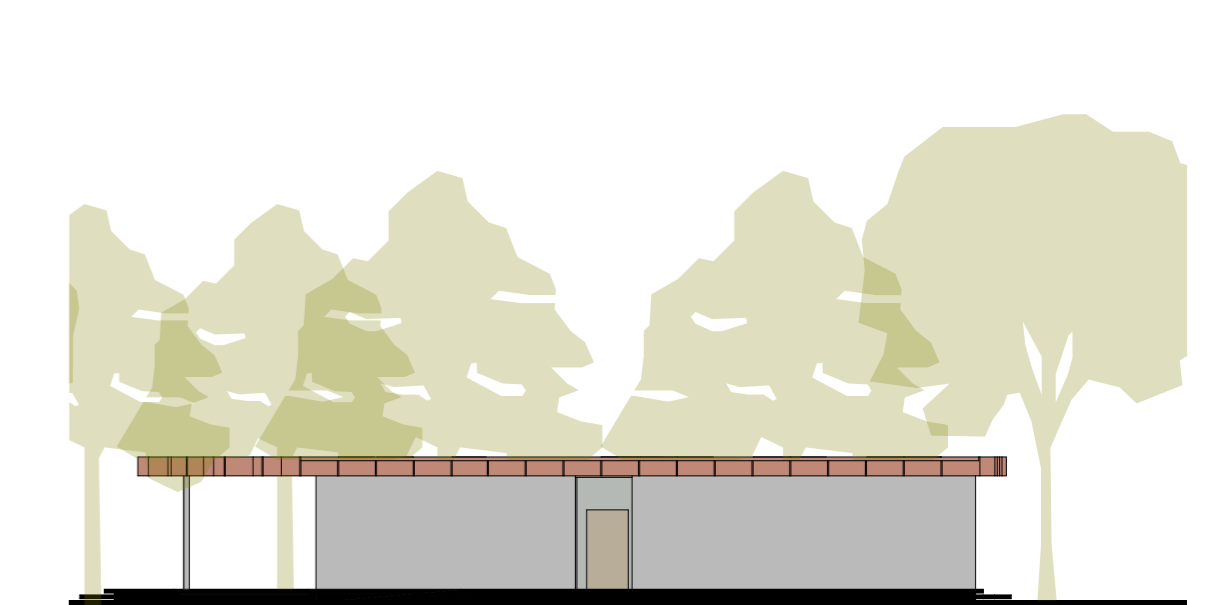

sjeverno pročelje 1:200

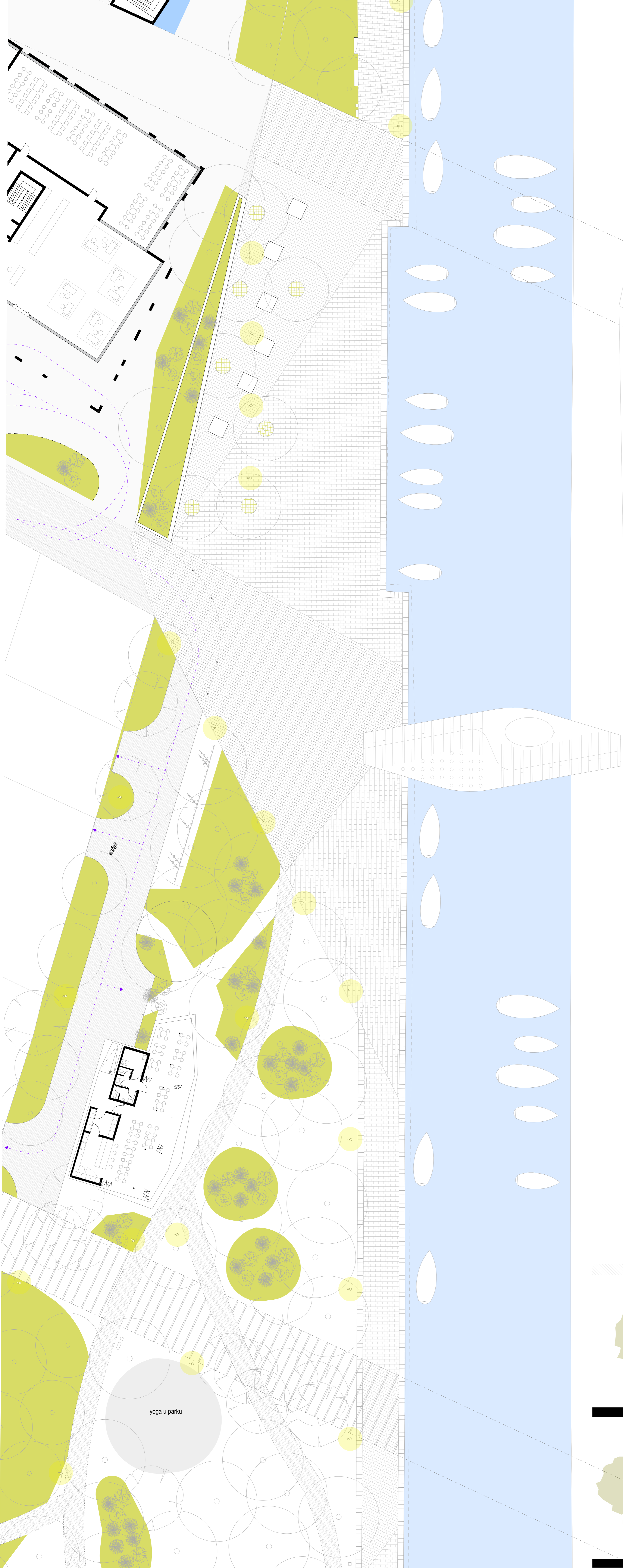

yoga u parku

# UREĐENJE SOLINA I TRAVARICE

NATJEČAJ ZA IZRADU IDEJNOG URBANISTIČKO - ARHITEKTONSKOG RJEŠENJA UREĐENJA KULTURNO-POVIJESNE CJELINE SOLINA I TRAVARICE U TROGIRU

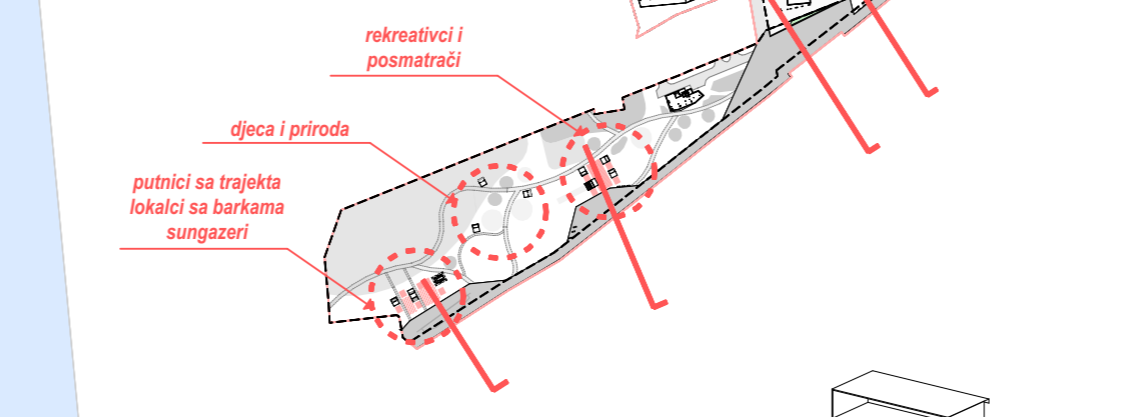
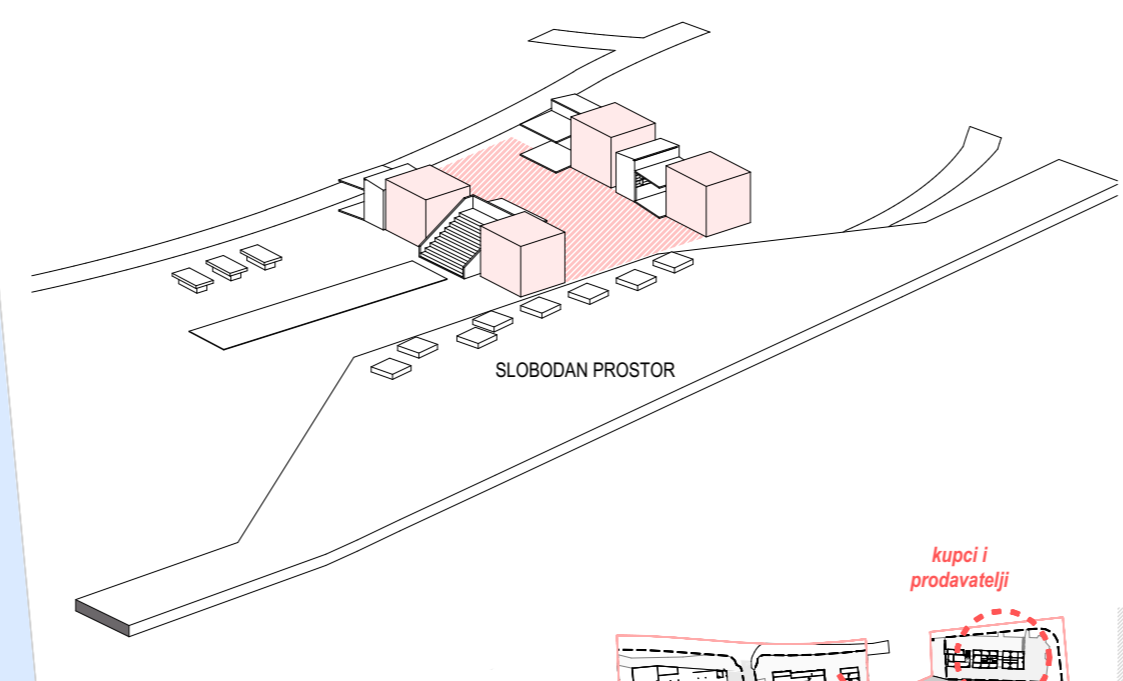
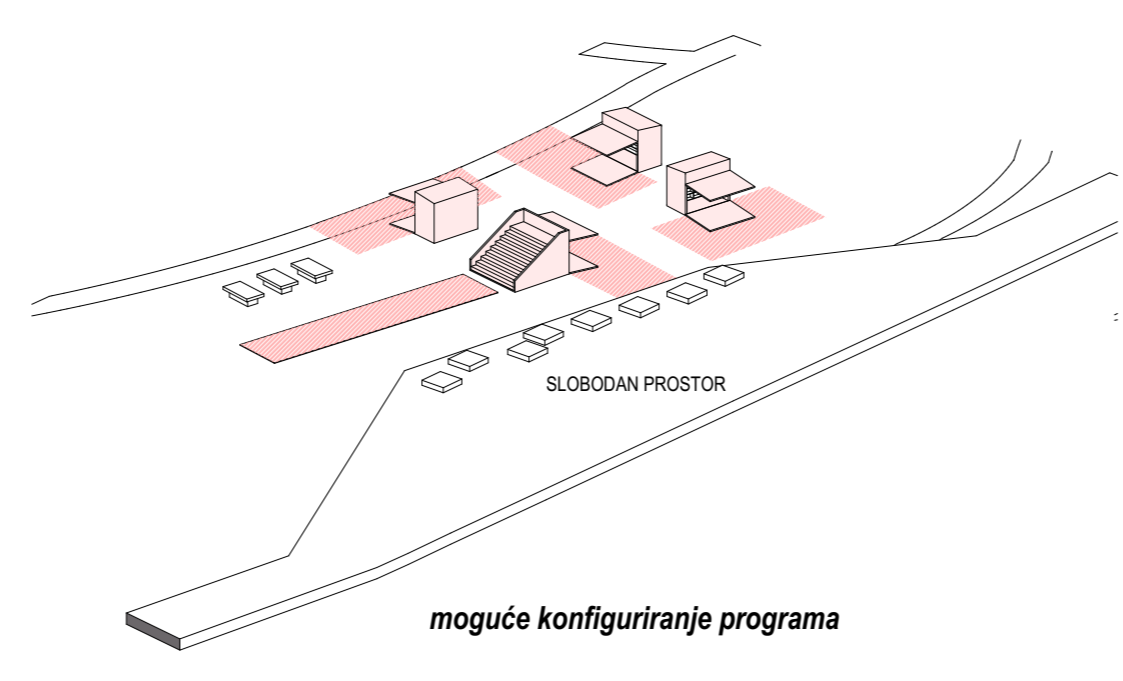
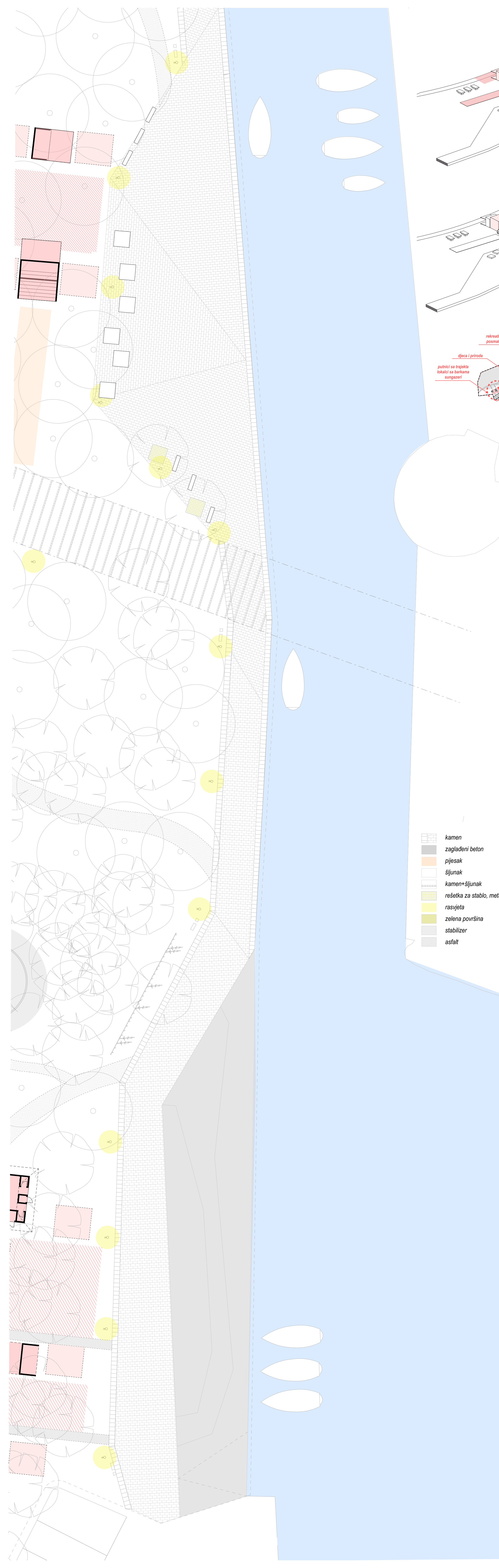
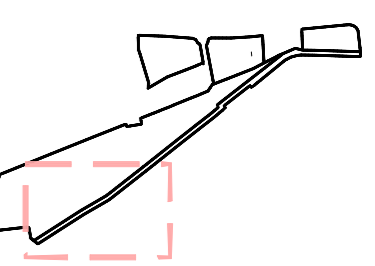

### PRIVREMENI OBJEKTI

TIP 1	TIP 2	TIP 3	TIP 4	TIP 5
hrana + znanje	kafica / gosti	pausa za umetnost	refleksija u parku	na sve strane
kiosk Argentinca spremiste	radionica za barke	renta kajaka	renta električnih bicikla	sanitarje + umetnost + upoznavanje
			obnovljena kapelica soba za pisco	kiosk viškonac našne spremiste bicikala

### PRODAJNA KLUPA I RASHLADNA VITRINA 1:50

dimenzije: 160x80x85  
debljina nogice 3x3cm  
staklena vitrina  
limena box

### PRODAJNI KIOSK 1:200

celokupna konstrukcija  
fasada iz celokupnog lima

- kamen
- zegljeni beton
- pijesak
- šljunak
- kamen+šljunak
- rešetka za stablo, metalna
- rasvjeta
- zelena površina
- stabilizer
- asfalt

